

BASKET RQG-18

**Self-Propelled
Tracked Access Platform**



BASKET RQG-18

Self-Propelled Tracked Access Platform

Specifications / Dimensions

Working height	18.2m
Outreach max (200kg)	8.0m
Outreach max (100kg)	11.0m
Length – stowed	4.7m
Width	0.89m
Height	1.99m
Total weight	2650kg
Engine	12KW Honda
Gradeability	25%
Driving speed stowed	2.5km/h
Turntable rotation	359 degrees
Platform size	1.20mx0.70m
Platform capacity	200kg
Platform rotation	70 degree + 70 degree

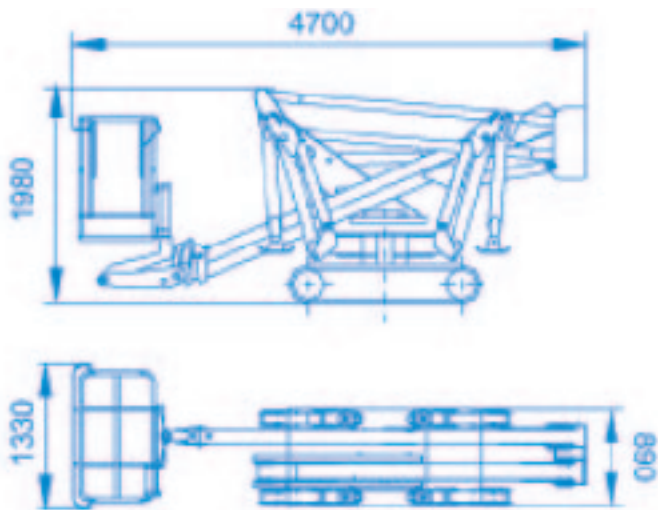

Standard Features

- Load limit device
- Hour meter
- Electric hydraulic controls
- Rubber crawler tracks
- Demountable cage

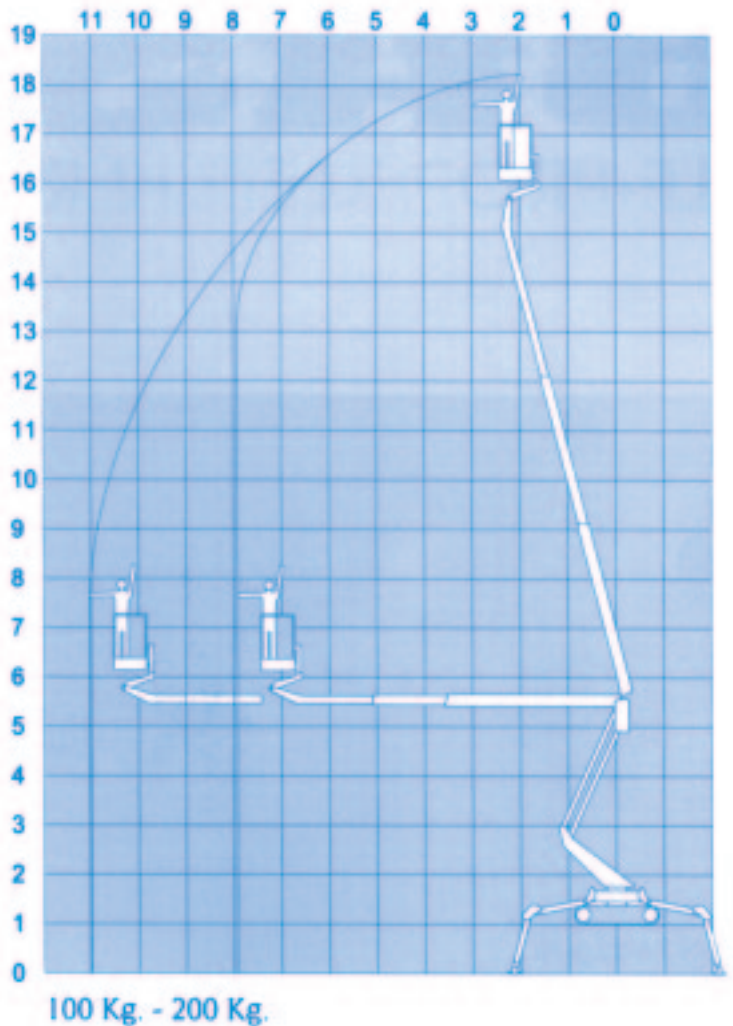

Rapid
PLATFORMS

London Road, Spellbrook, Bishop's Stortford,
Hertfordshire CM23 4AU

Tel: 01279 501 501

Fax: 01279 501 100

E-mail: info@rapidplatforms.co.uk

Web site: www.rapidplatforms.co.uk